

Peter Chapman,  
Bang & Olufsen A/S, Struer, Denmark

Presented at  
the 108th Convention  
2000 February 19-22  
Paris, France



**AES**

*This preprint has been reproduced from the author's advance manuscript, without editing, corrections or consideration by the Review Board. The AES takes no responsibility for the contents.*

*Additional preprints may be obtained by sending request and remittance to the Audio Engineering Society, 60 East 42nd St., New York, New York 10165-2520, USA.*

*All rights reserved. Reproduction of this preprint, or any portion thereof, is not permitted without direct permission from the Journal of the Audio Engineering Society.*

**AN AUDIO ENGINEERING SOCIETY PREPRINT**

# COMPLETE THERMAL PROTECTION OF AN ACTIVE LOUDSPEAKER

Peter John Chapman  
Electroacoustics Research & Development  
Bang & Olufsen A/S  
Struer, Denmark

*e:mail* PCP@Bang-Olufsen.DK *fax* 00 45 97 84 12 50

## 1 Abstract

The paper describes the implementation of thermal protection in an active loudspeaker. The protection system has been designed to protect the loudspeaker drive units from any signal that would cause thermal damage to the units. The protection has also been designed so that the loudspeaker can generate the maximum sound pressure level for the longest period of time and to be subjectively acceptable.

## 2 Introduction

A great problem for loudspeaker designers is the need to produce more and more sound pressure level and sound quality from smaller cabinets and on a budget. The limiting factor of retail price means that for domestic loudspeakers it is not possible to use professional drive units and cheaper units have to be used which have a lower sensitivity and lower power handling compared to the professional units.

Consequently, to generate the high sound pressures desired, large amplifiers are necessary to push the drive units to their limit. Large amplifiers are also needed to cope with electronic boost that is often applied to achieve deep bass from small cabinets and to avoid audible clipping of the signal in the amplifier that may otherwise occur. Thus the power amplifier output capability will, most likely, far exceed the long term power handling of the drive units.

The paper describes briefly the development of an active 3-way loudspeaker which had to fulfil the requirements of playing very loud, with limited driver capability, and achieve good bass performance in a small cabinet. Furthermore, to achieve the quality of sound desired at higher sound pressure levels, large amplifiers had to be included in the design.

For this paper, however, the focus of the design was the aim that it should not be possible to damage the loudspeaker units by overheating with any input signal to the loudspeaker at any amplitude. Therefore, the core of the paper is the description of the thermal protection system designed to protect the drive units. Part of the protection system developed, that for the low frequency drivers, employs thermal modelling of the drivers developed in earlier work [1].

Another requirement of the complete loudspeaker system was that it should be subjectively acceptable (such that the loudspeaker appears to play normally when the protection is active). To achieve this, further refinement of the protection system was necessary. The work and the resulting functionality of the system is described together with its operation with different types of music and test signals.

The system was implemented almost entirely with analogue electronics with only a minor part controlled with a microprocessor. The system has been effected in a production loudspeaker and thus copes with the tolerances experienced in a production environment.

### 3 Development Of An Active 3-Way Loudspeaker System

The loudspeaker system in which the thermal protection system has been implemented was not built specifically for the purpose of implementing the protection, rather the opposite. The physical external design for the loudspeaker system was already complete from the designer, as to were the desired specifications because the new loudspeaker system would replace an existing system on the market and out-perform it. Therefore, thermal protection was a tool to be implemented to achieve the desired specifications and performance.

#### 3.1 Design Constraints And Desired Specifications

The completed loudspeaker design would have an overall cabinet volume of 27 litres which includes the acoustic space and electronics. The physical cabinet is a tall aluminium profile 1800 mm in height with a depth of 100 mm at its maximum. The front baffle is 160 mm wide.

The desired specifications for the loudspeaker system immediately relevant to the use of thermal protection where the systems' *frequency range* and *maximum sound pressure level* (measured in accordance with IEC 268-1/3/5). The system should have a lower cut-off frequency of 40 Hz (-10 dB) and generate a maximum sound pressure of greater than 103 dB for a stereo pair at 3.5 m in our standard IEC listening room measuring 6.0 x 5.1 x 2.4 m.

#### 3.2 System Design

The above requirements could be achieved with two 150 mm diameter bass drivers, a 76 mm midrange unit and a 25 mm tweeter driven with sufficient amplifiers within each loudspeaker. This would also not exceed the product budget. The drive units where optimised for the task including a special basket for the bass drivers so they would fit in the narrow baffle. The midrange unit was also fitted with a special rear cup to isolate it from the bass drivers.

Through extensive listening tests it was concluded that the loudspeaker cabinet must be closed as a ported version gave many problems including poor transient response and port noise due to the physical limitations of the port dimensions. The closed cabinet and bass driver combination was further optimised to an 8 litre volume for each bass driver with a combined Q of 0.8 and a -3 dB frequency of 85 Hz. To achieve the low frequency cut-off desired, the low frequency response of the system was boosted with an electronic low-shelf giving 3.8 dB of lift below 80 Hz. The boost gave a new -3 dB frequency of 60 Hz and achieved the lower cut-off frequency desired. The response of the system (driver and cabinet), the electronic boost, and the total low frequency system response including boost are shown in figure 1.

The physical placement of the drive units in the cabinet and the layout of the loudspeaker is shown in figure 2. The two bass drivers are placed in separate sealed enclosures and are positioned in the cabinet to minimise the excitement of standing waves. Any remaining effects of standing waves within the cabinet are completely removed with damping material. The drive units are also positioned vertically in-line and at a height that gives an optimum image

placement when listening at a standard listening height when the listeners' ears are approximately 1 m above floor level.

### 3.3 Amplifier Requirements And Output Power

Three amplifier modules are used to drive bass, midrange and tweeter units. Crossover frequencies between the bass and midrange and midrange and tweeter lie at 800 and 4000 Hz respectively. To achieve the maximum sound pressure from the bass drivers, the bass amplifier was dimensioned such that it was capable of moving the bass units to their limiting displacement of +/- 8 mm at 100 Hz without amplifier distortion. 100 Hz was chosen as a critical frequency as it lies in the frequency range that delivers the largest dynamic effect in the bass content of most music. This level would also generate the desired maximum sound pressure level in the bass region. The dimensioning was verified through listening and experimentation with amplifiers able to deliver between 80 and 1200 W into each 8 ohm bass driver. The chosen amplifier size was 150 W for each bass driver implemented as a single 300 W amplifier driving the two bass units in parallel thus loading the amplifier with a nominal 4 ohm load. Midrange and treble amplifiers were consequently dimensioned to 75 W into 8 ohms to match the performance in the bass. The *long term maximum output power* (measured in accordance with IEC 268-3) of the 3 amplifiers was measured as:

Bass	450	W
Midrange	120	W
Treble	120	W

This is the maximum power that the individual amplifier modules could deliver into their load.

### 3.4 Protection Of The Bass Drivers Mechanically

Due to the high power capability of the bass amplifier and the electronic boost applied to the signal, the limiting displacement of the bass units can be exceeded at low frequencies, below approximately 150 Hz. Figure 3 shows the theoretical displacement of ideal bass units based on their small signal parameters when swept with an unclipped sine wave at the amplifiers maximum output. Without protection of the bass drivers from overly large signals at these frequencies any impulsive signals will be reproduced with a familiar 'gokking' sound and ultimately mechanical damage of the units will result.

To protect the bass units from mechanical damage a protection circuit is used. ABL (Adaptive Bass Linearisation) [2] is a circuit that limits high amplitude low frequency signals before the amplifier. The response of the circuit is tailored to the response of the loudspeaker and its behaviour at high amplitudes. The circuit is inactive at low signal amplitudes but becomes progressively more active as the signal level increases above the level where the bass units are close to their displacement limit. As the signal diminishes the circuit becomes inactive once again. The frequency response of the circuit at several signal amplitudes is shown in figure 4. The ABL response has also been extended to mid-bass frequencies to reduce clipping in the amplifier at very high levels. With the ABL circuit in place it is now no longer possible to reach the displacement limit of the bass drivers or clip the amplifier so that it is audible with music. Figure 5 shows the basic block diagram of the loudspeaker system.

### 3.5 Drive Unit Power Handling

It is normal in loudspeaker development and production to measure various power handling specifications for the drive units especially during development of new units. The tests are extremely important to determine longevity of the units and to identify any flaws in the design of the units mechanically. One measurement is the *rated noise power* of the drive unit. This specification is the maximum power the drive unit can withstand when exposed to 100 hours of continuous noise. The noise signal is *simulated programme signal* in accordance with IEC 268-3/5 with a crest factor of 6 dB. The rated noise power for the drive units (measured with the drive units mounted in the correct cabinet and with the correct crossover filter and bass boost without mechanical protection) represents the long term power handling of the units in the loudspeaker. The rated noise power was measured as,

Bass units	39	W	(8 ohms)
Midrange	21	W	(8 ohms)
Tweeter	6	W	(8 ohms)

Optimisation of the construction of the drive units mechanically meant that these power handling limits are caused by the units being close to their thermal limit i.e. higher power will cause the units to be damaged by overheating.

## 4 Requirement For A Thermal Protection System

By simply comparing the long term maximum output power capability of the amplifiers and the rated noise power handling of the drive units it is clear that playing very loud for even a short period of time will inevitably burn some, if not all, of the drive units. Also, as the loudspeaker system is active and hence all electronics are inbuilt in the loudspeaker then the customer has a tendency to expect that the loudspeaker can hold to whatever input is presented at whatever level because they do not have the possibility of mismatching amplifiers and speakers. This mismatching has already been performed to get more out of the loudspeaker than has been possible before. Therefore, protection of the drive units must be included.

### 4.1 Design Considerations

Several points had to be considered in the design process of a thermal protection system. The following points were most critical,

- The protection system should not have adverse effects on the timbral balance of the loudspeaker.
- The operation of the protection system should be subjectively acceptable.
- The protection should not compromise the ability of the loudspeaker to play loud.
- The protection system should be implemented with analogue electronics in the main (a small part may be implemented in a microprocessor).
- It should not be possible to damage the loudspeakers with any signal.

These points are discussed in the implementation of the thermal protection system.

## 5 Implementation Of The Thermal Protection System

The implementation phase can be divided into two stages,

- 1) Determination of driver temperatures
- 2) Gain control

To allow accurate protection of the drive units the operating temperatures within each of the drive units must be known. Once the temperatures are known then an appropriate method of gain control can be developed.

### 5.1 Determination Of Driver Temperatures

Due to the differing electronic design of the bass amplifier and midrange and treble amplifiers, two different methods to determine the driver temperatures were implemented.

#### 5.1.1 Temperatures Of The Bass Drivers

The bass amplifier has a differential output such that the two output terminals both generate the signal across the bass drivers. Therefore, due to the amplifiers output configuration, it is not possible to apply a small dc current over the drive units and use a measurement of the change in dc resistance  $R_e$  of the voice coil to obtain the voice coil temperature directly. If measuring the voice coil temperature electrically was not an option then an alternative was to have a temperature probe or thermocouple inserted directly into one of the bass drivers during assembly of the driver. However, this alternative is much too expensive and subject to many tolerances. Another alternative was needed.

##### 5.1.1.1 Thermal Modelling The Bass Drivers

A final option was to use a thermal model of the bass driver and with the amplifier output use the model to simulate the temperatures within the bass units. Earlier work [1] describes the development of an accurate thermal model for moving coil loudspeakers. The model is shown in figure 6. The model is a third order model with three time constants. The temperatures given by the third order model, indicated in figure 6, are the voice coil temperature  $T_{vc}$ , the magnet temperature  $T_m$  and a third temperature  $T_g$  relating to the gap temperature or the temperature of the magnet surface close to the voice coil, above ambient. The signal flowing into the model is the power  $P$  flowing into the voice coil. The thermal parameters in the model were measured for the bass drivers following the measurement technique described in [1]. Briefly, the technique measures the rise in temperature of the voice coil during application of a sine wave at a frequency where the impedance of the unit is resistive (step response). The model is then fitted to the measurement of the unit.

The thermal parameters of the model were measured to be,

$$\begin{array}{rcl}
 R_1 & = & 3.1 \text{ } ^\circ\text{CW}^{-1} \\
 R_2 & = & 1.2 \text{ } ^\circ\text{CW}^{-1} \\
 R_3 & = & 3.3 \text{ } ^\circ\text{CW}^{-1}
 \end{array}
 \qquad
 \begin{array}{rcl}
 C_1 & = & 2.4 \text{ } \text{Ws}^\circ\text{C}^{-1} \\
 C_2 & = & 16 \text{ } \text{Ws}^\circ\text{C}^{-1} \\
 C_3 & = & 983 \text{ } \text{Ws}^\circ\text{C}^{-1}
 \end{array}$$

The three time constants in the model are therefore,

Voice coil	$R_1C_1$	=	7.4	s	
Gap	$R_2C_2$	=	19.2	s	
Magnet	$R_3C_3$	=	3240	s	(54 minutes)

A problem arises here with implementation of the model with analogue electronics, that of the long time constant of the magnet system. To solve this, the model can be adjusted to remove the magnet time constant with the addition of the magnet temperature directly into the model. Figure 7 shows the modified model.

With a measurement of the magnet temperature of one of the bass drivers directly then the model comprises of the two short time constants only. For measurement of the magnet temperature several experiments were undertaken regarding placement of a measuring probe and the type of probe itself. In terms of electronic construction, the optimum solution was to use a NTC (negative temperature coefficient) resistor. Placement of the resistor was investigated by measuring the temperature rise of the magnet system at several points around the magnet when a signal was applied to the voice coil according to the measurement method mentioned for calculation of the thermal component values. The measurement points are shown in figure 8. Points 1 and 2 are at different depths within holes bored into the pole piece of two units. Points 3 and 4 are on the rear side of the magnet structure with point 4 placed on a small pcb. Point 5 is on the outer edge of the magnet system. For the measurements a sine wave at 300 Hz and 11 Vrms was used. The final steady state temperatures measured were,

Point 1	70.0	°C		
Point 2	68.1	°C		
Point 3	66.8	°C	(Point 3'	67.0 °C)
Point 4	66.3	°C	(Point 4'	66.6 °C)
Point 5	59.2	°C		
Ambient	27.3	°C		

From the temperature measurements it was clear that point 5 was not suitable due to a significantly lower temperature than the core of the magnet and this position also presents physical mounting problems. Boring a hole into the pole piece also increases the cost of the drive unit and ensuring the NTC is placed correctly in the hole with no air gaps to reduce heat transfer gives production problems. However, points 3 and 4 measure a temperature that is sufficiently close to the core temperature of the magnet and a temperature curve that follows closely the rising temperature of that measured at points 1 and 2 (within 4 °C). Point 4 also represents a realistic mounting option if the NTC is fixed on a pcb together with a connector. The chosen solution is shown in figure 9, where the NTC resistor is a surface mount component mounted on a pcb which is screwed to the magnet system.

The magnet temperature can now be used with the thermal model in figure 7 to derive the voice coil temperature. The last remaining parameter in the model is the power flowing into the drive units or model, P.

$R_e$  at a temperature  $T$  for a voice coil wound from copper wire is given by the first order equation below,

$$R_e(T) = R_e(T_0)[1 + \alpha(T - T_0)] \quad \text{Eqn 4}$$

Where,  $\alpha$  is the temperature coefficient of copper ( $0.004 \text{ K}^{-1}$ ) and  $R_e(T_0)$  is the dc resistance of the coil at ambient temperature where the system has been calibrated.

The midrange and treble amplifier outputs are decoupled from the drive units by a capacitor and are therefore not influenced by the presence of the dc signal. A dc current of 40 mA is used. The nominal dc resistance of the midrange and tweeter units at  $20^\circ\text{C}$  are 6.9 ohms and 6.2 ohms respectively. Included in the derivation of temperature are production tolerances in the driver unit dc resistance value, in this case  $\pm 5\%$ . The temperature calculated is arranged to be 5% higher than indicated by the nominal dc resistance. The change in dc voltage is measured by filtering the signal across the driver with a 2<sup>nd</sup> order low pass filter with a cut off frequency of approximately 30 Hz. Rejection of any ac signal from the amplifiers is also aided by the fact that the crossover filters for the midrange and tweeter include 4<sup>th</sup> order high pass filters at 800 Hz and 4000 Hz respectively. Therefore, the combined effect of the low pass filter and the crossover give an ac amplifier signal rejection of greater than 80 dB.

## 5.2 Gain Control

With a knowledge of the working temperatures of each of the drive units it is now possible to use this knowledge to protect the units by introducing gain reduction of the signal to the drive units. The gain reduction required is dependant upon the individual drive unit limits.

### 5.2.1 Temperature Limitations Of The Individual Drive Units

The bass drivers are constructed with a copper voice coil on an aluminium coil former and a ferrite magnet system. The operation of the units is guaranteed with a voice coil temperature up to  $200^\circ\text{C}$  with heat damage occurring at temperatures above  $250^\circ\text{C}$ . The magnet can stand temperatures well in excess of  $200^\circ\text{C}$  without problems.

The midrange unit is constructed from a ferrite magnet and copper voice coil. However, in this case it is heat transfer from the coil through the former to the dome material that gives a limit to the highest operating temperature. From measurements it was determined that gain reduction should begin at voice coil temperatures as low as  $120^\circ\text{C}$ .

The tweeter is constructed with a copper voice coil and neodymium magnet with the gap filled with ferrofluid. The voice coil can operate to  $200^\circ\text{C}$ , however, neodymium type magnets begin to lose flux for temperatures much above  $90^\circ\text{C}$  [3]. For this reason the voice coil temperature is limited to protect the magnet and gain reduction should begin for a voice coil temperature of approximately  $125^\circ\text{C}$ .

### 5.2.2 Gain Reduction Curves For Each Drive Unit

Figures 13, 14 and 15 show the approximate gain reduction curve in dB versus voice coil temperature in  $^\circ\text{C}$  for each of the drive units. The gain control is introduced in the electronics using voltage controlled amplifiers (VGA's) where the voice coil temperature of each of the



### 5.1.1.2 Calculation Of Power Flowing In The Bass Drivers

The power flowing into the model is a function of time, frequency (due to the complex impedance of the unit in the cabinet) and voice coil temperature (due to the change in dc resistance of the voice coil), or  $P(t,f,T_{vc})$  which is given by,

$$P(t,f,T_{vc}) = [i(t,f,T_{vc})]^2 R_e(T_{vc}) \quad \text{Eqn 1}$$

Where  $i$  is the current flowing in the voice coil and  $R_e$  is the dc resistance of the voice coil. The current is given from the voltage across the voice coil  $v$  and the impedance of the driver in the cabinet  $Z$ , or the admittance function  $Y$ ,

$$i(t,f,T_{vc}) = v(t) \frac{1}{Z(f,T_{vc})} = v(t) Y(f,T_{vc}) \quad \text{Eqn 2}$$

We have a knowledge of, and access to, the voltage from the output of the bass amplifier  $v(t)$  and the drive unit impedance in the cabinet  $Z(f,T_{vc})$ . However, it is not possible to include an impedance function that is a function of temperature in the electronic design. As a compromise it is necessary to select an appropriate fixed condition for the impedance function  $Z$ . Therefore, the power signal can be derived by,

$$P(t,f) = [v(t) \frac{1}{Z(f)}]^2 R'_e = [v(t) Y(f)]^2 R'_e \quad \text{Eqn 3}$$

The actual impedance function of one bass unit in the cabinet is shown in figure 10 measured at a temperature of 20 °C. To obtain the power from the amplifier output voltage in the electronics, the voltage is first filtered with an equaliser that simulates the drive unit admittance curve (figure 11). The signal  $v(t)Y(f)$  is then squared by use of an operational amplifier circuit where the feedback resistance is a function of the input voltage. The response of the circuit is shown in figure 12 where the amplifier output voltage has been swept at a fixed frequency. The output is now directly proportional to the power  $P(t,f)$  which is simply scaled and delivered into the thermal model.

The power that has been calculated is independent of the effect of rising voice coil temperature such that the power will be higher than in practice as the electronics to calculate the power 'sees' a constant coil resistance, that at a temperature of approximately 25 °C. However, the thermal model has a constant reference of the magnet temperature measured directly to correct the simulated voice coil temperature. Also, the simulation will always be on the safe side such that the electronics will give a slightly higher voice coil temperature and thus protect earlier.

### 5.1.2 Temperatures Of The Midrange And Tweeter

The voice coil temperature of the midrange and tweeter units is obtained in a different way to the bass drivers. Due to a more conventional amplifier output configuration it is possible to use a direct measurement technique.

By exploiting the increase in dc resistance of the voice coil with increased temperature it is possible to calculate the voice coil temperature by using a small constant dc current through the coil and to measure the change in dc voltage.

drive units is used to control the gain reduction of the signal. The gain reduction is instantaneous such that as soon as the voice coil temperature rises over the defined limit the gain is reduced by the level defined on the curve. The curves show that a maximum gain reduction of 14 to 18 dB is possible. During operation, the gain reduction is monitored by a microprocessor (which is used primarily for controlled start-up and shutdown of the loudspeaker system). The microprocessor monitors the gain signal at intervals of 50 ms. If the maximum gain reduction is reached in any one of the three bands for a period of 250 ms then the microprocessor mutes and shuts down the complete loudspeaker system. To restart the system must have the mains supply removed and reconnected.

Initially, a maximum gain reduction of 15 to 18 dB appears to be a huge amount of gain reduction and the system was first designed to give a 10 dB reduction in each band. However, a mute condition was all too easily achieved. This is due to the fact that the amplifiers will be clipping at high sound pressure levels and therefore a decrease in input level will not give an equal decrease in output level from the amplifier until the input has been reduced so that the amplifier is no longer clipping. With an input signal amplitude of greater than approximately  $2 V_{\text{peak}}$  able to clip the bass amplifier and greater than  $1 V_{\text{peak}}$  able to clip the midrange and treble amplifiers and a potential input amplitude of  $9 V_{\text{peak}}$  from a Bang & Olufsen master then to reduce the input signal so that the power output from the amplifiers is lower than the drive unit power handling it is clear that a potential 15 to 18 dB reduction is required.

Once the determination of gain reduction was in place, how the gain in each band effected the other bands and how the gain control functioned became very critical, not only for practical reasons, but also for subjective reasons.

### 5.2.3 Initial Implementation - Equal Reduction In All Three Bands

To satisfy the first design consideration, it was decided initially that any reduction in gain should be common to all drivers so that the timbral balance was maintained when the protection became active.

This was implemented by monitoring the gain reduction signal from all three bands and using the largest gain reduction value at any time to control equally the gain of all three bands. To avoid pumping effects in the sound pressure level generated by the loudspeaker (when the temperature rises and falls rapidly in a repeated manner), a hold circuit was used to give a slow release time so that the gain does not rapidly return to normal as the temperature falls. An example of the gain reduction as a function of time for a single temperature spike is shown in figure 16.

This method of gain control was extensively tested with various types of test signals including sine waves, pink noise and noise with a spectrum in accordance with IEC 268-5 'Simulated Programme Signal'. The system was also tested with music. It was clear that under no circumstances was it possible to damage the drive units even with burst signals at all input levels. However, during listening tests it was quickly apparent that this method of gain control was only acceptable subjectively with signals of a reasonably constant nature and having broad band frequency content because the drive units would reach the range of gain reduction relatively slowly.

With signals containing short bursts of narrow band frequency information the system would, without warning, reduce the gain by a significant amount which was perceived almost as if someone had turned off the system (likened to a party situation when someone suddenly stops the music to change the CD). After investigation it was seen that the gain reduction experienced was indeed necessary to protect the units, however, it was only the midrange and most often the tweeter giving the gain reduction signal due to their much shorter thermal time constants. One piece of music used for testing was a track by 'Fat Boy Slim' where during the track a square wave is swept through the mid and high frequency area causing approximately 120 W to be delivered to the tweeter over a period of several seconds when played a full volume. Another solution for the gain control was necessary.

### **5.2.4 Final Implementation - More Complex Gain Control**

To remove the problem of turning down all three bands and hence suffering with a system that did not work subjectively it was necessary to remove the common gain reduction between the bands.

The first experiment enabled all three bands to operate individually where the temperature of the particular drive unit was used only to control the gain in that band. Each band also included the slow release. The resulting functionality was much improved as the sudden drops in sound pressure were no longer present. However, it was now possible for the timbral balance of the loudspeaker to be changed to a large degree. The biggest problem was that situations occurred when, for example, only the midrange was attenuated. This meant that in most instances when the protection became active it was not pleasant to listen to the loudspeaker playing.

After extensive listening tests an optimum solution was devised where the three bands are linked but are free in some ways from each other. The best solution and the solution implemented was to allow gain reduction in the tweeter to occur without influence on the midrange and bass. However, if the gain in the midrange was reduced then this would also reduce the tweeter by the same number of dB's but would not influence the bass channel. In this situation it is not possible for the tweeter to play at a higher level than the midrange and it also helps to reduce the temperature in the tweeter further. When the midrange was reduced, it was also arranged such that the tweeter was free to be attenuated even further if necessary. The remaining possibility is when the bass units become too hot. In this case the gain reduction in the bass channel also reduces the gain in the midrange and treble by the same amount but the midrange and tweeter are free to have further gain reduction.

This optimisation meant that the timbre could only be tilted down at higher frequencies and the conclusion from listening tests was that subjectively this method was very acceptable to such an extent that at the highest sound pressure levels the tilting of the response by the protection made the loudspeaker system more preferable.

As a final optimisation the slow release circuit for the tweeter gain control was removed due to the short time constant of the tweeter voice coil being 0.8 s and hence after any temperature spikes the temperature falls rapidly. This helped subjectively as it was almost no longer possible to hear that attenuation of the tweeter was occurring due to the high sound pressure level.

## 6 Summary Of The Functionality Of The Protection System

For determination of the bass driver voice coil temperature, the system uses a thermal model together with a measurement of the magnet temperature and the power signal calculated from the output from the bass amplifier. The temperatures of midrange and tweeter are determined from a direct measurement of the increase in dc coil resistance  $R_c$ . The temperatures are used with defined gain reduction curves for each driver and a linked gain control system to give a subjectively acceptable performance. A block diagram of the complete system is shown in figure 17. The system has been tested with all types of signals and fulfils the design considerations,

- The protection system does not have adverse effects on the timbral balance of the loudspeaker and makes the system more preferable at very high levels.
- The operation of the protection system is subjectively acceptable.
- The protection does not compromise the ability of the loudspeaker to play loud and the system has been measured generating an average sound pressure level of 105 dB for a stereo pair measured at 3.5 m from the loudspeakers in our standard listening room with noise according to IEC 268-5 'Simulated Programme Signal'.
- The protection system has been implemented with analogue electronics and uses a microprocessor to control a mute condition only.
- It is not possible to damage the drive units with any input signal.

## 7 Conclusion

With requirements for loudspeaker designers to produce more and more sound pressure level, deep bass and sound quality from smaller cabinets with limited driver area and with drive units of 'mediocre' sensitivity, large amplifiers are necessary giving an output capability that far exceeds the power handling of the drive units. Consequently the drive units are easily damaged by overheating and to avoid this, protection of the drive units is necessary.

A thermal protection system for an active loudspeaker has been developed and employs different techniques for determination of voice coil temperatures in the different drive units. The protection system has been proven to protect the loudspeaker against all types of input signals of all amplitudes, to be subjectively acceptable and not compromise the ability of the loudspeaker to play loud.

The loudspeaker system described is a production loudspeaker and hence production tolerances have been included in the design process so that all loudspeakers are protected to the same standard. The loudspeaker system is the Beolab 1 from Bang & Olufsen.

## 8 Acknowledgements

Many thanks for their assistance to Gert Munch and Bjorn Barfoed, Egon Bjerre and Claus Rasmussen with implementaion of the electronics, and especially Jan Larsen for his endless discoveries of 'worst-case' programme material, all of Bang & Olufsen.

## 9 References

- [1] 'Thermal Simulation of Loudspeakers', P.J.Chapman, a paper of the 104th AES Convention, Amsterdam, preprint No 4667, May 1998.
- [2] ABL, US Patent No 5481617 "Loudspeaker Arrangement with Frequency Dependant Amplitude Regulation" Egon Bjerre, Bang & Olufsen A/S.
- [3] 'Heat Dissipation and Power Compression In Loudspeakers', D.J.Button, J. Audio Eng. Soc., Vol 40 No 1/2, January/February 1992.

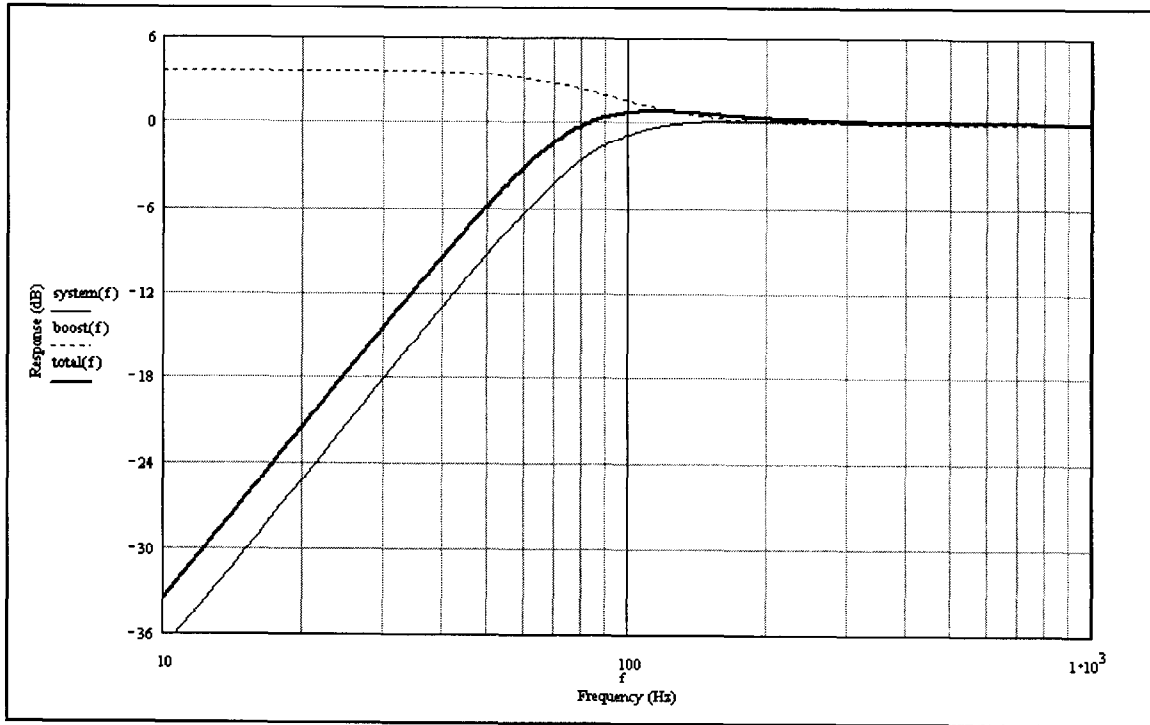

Figure 1 Low frequency system response.

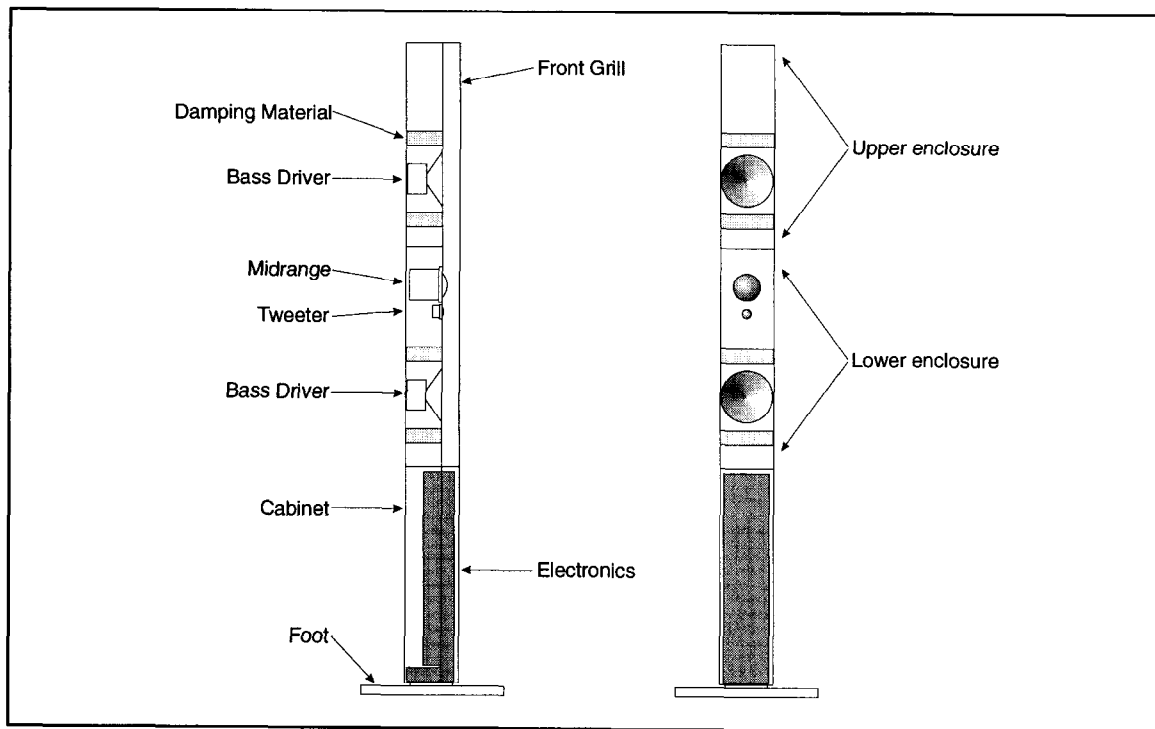

Figure 2 Loudspeaker layout.

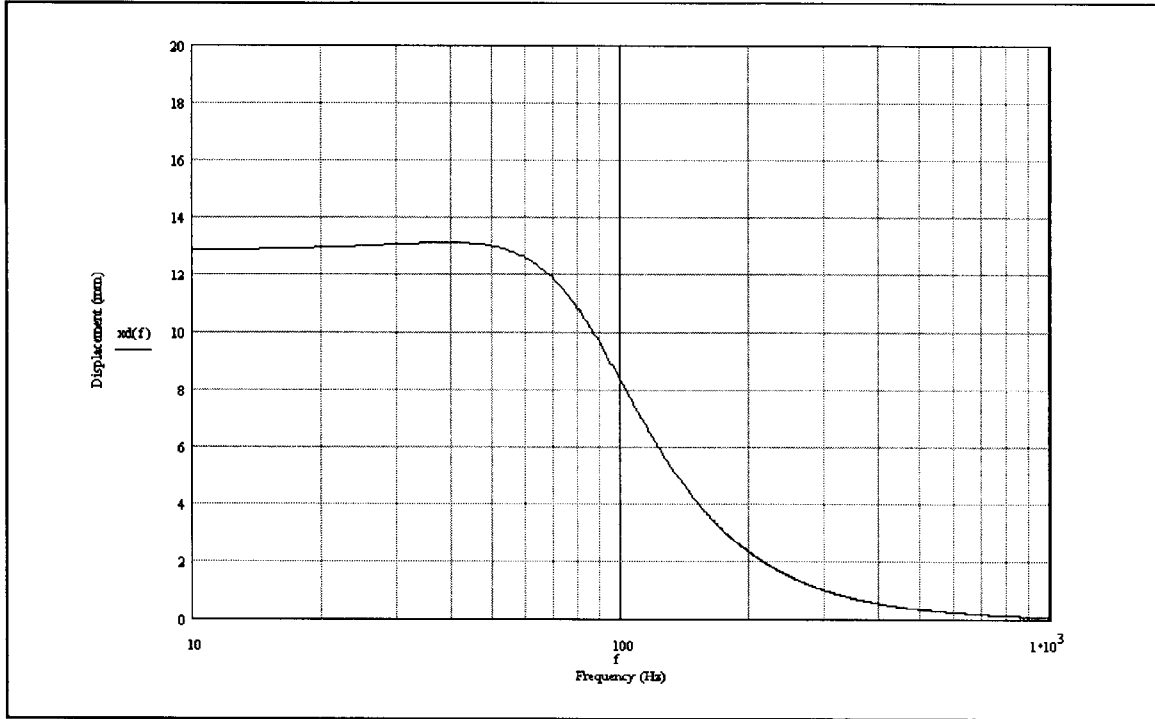

Figure 3 Theoretical displacement of the bass drivers if unlimited by non-linearities.

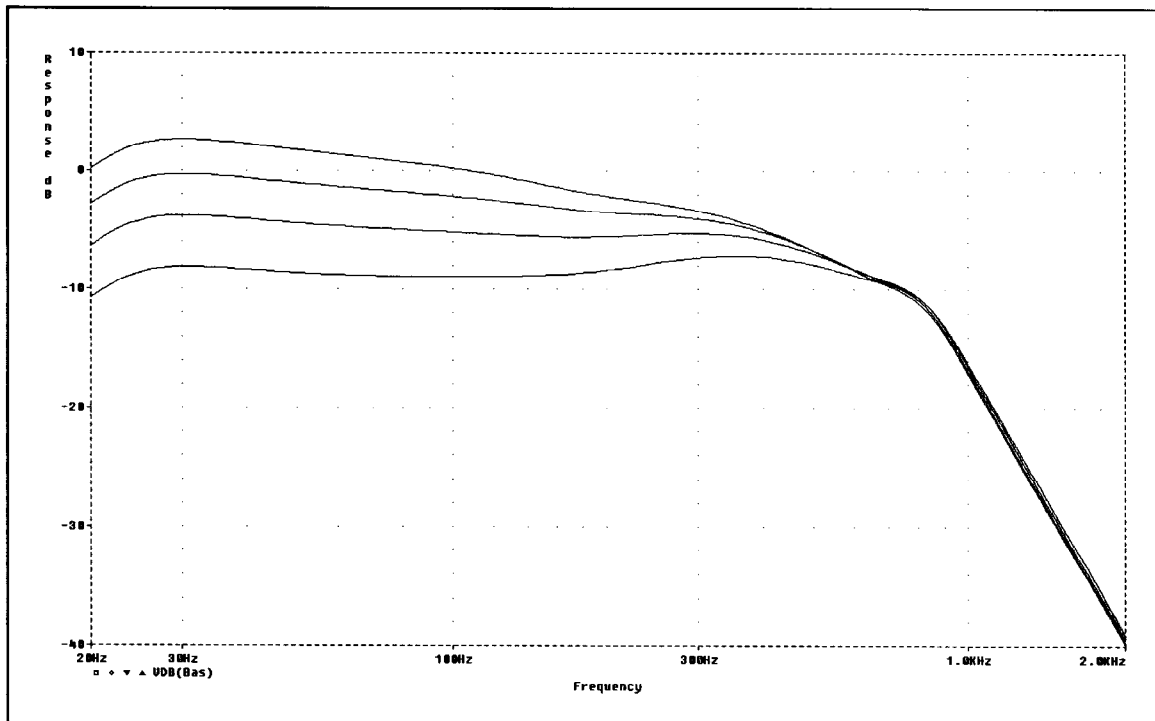
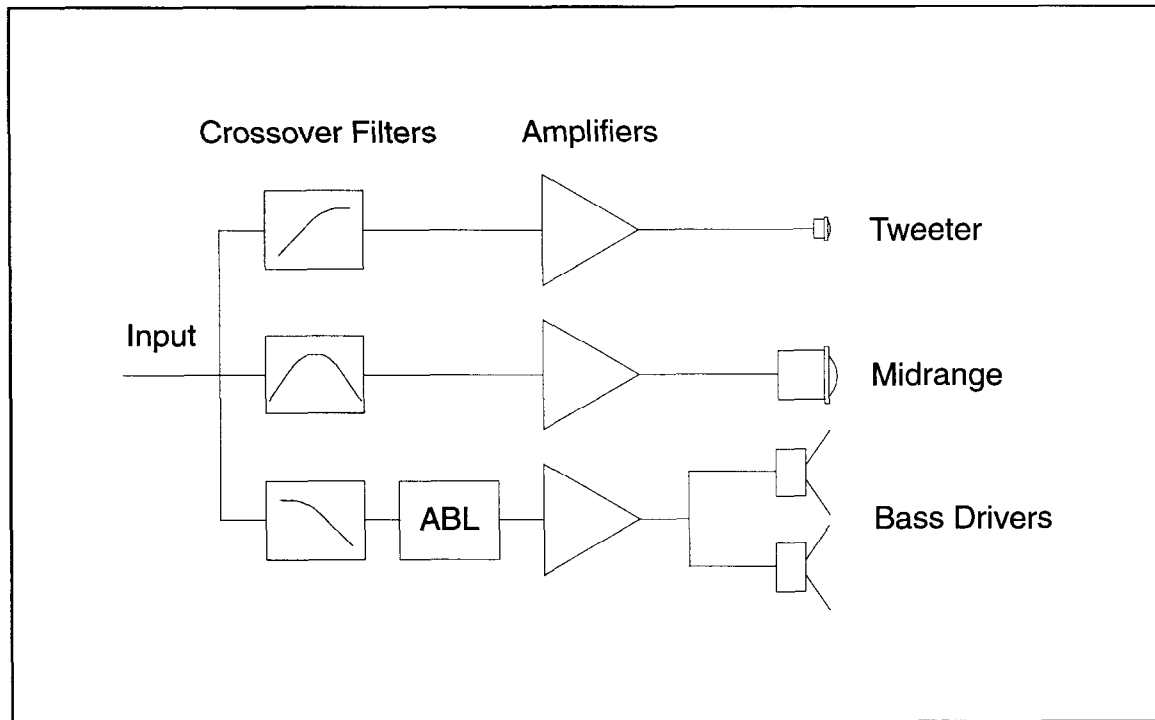
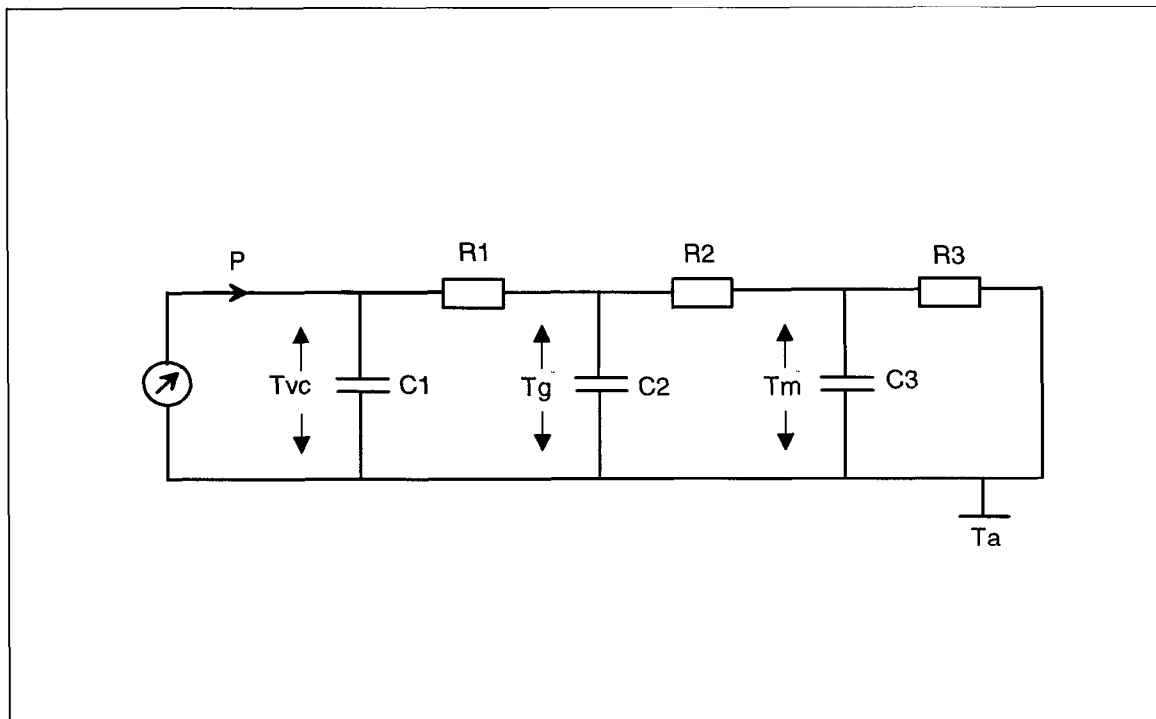

Figure 4 Frequency response of the bass crossover showing the ABL circuit functionality at various signal amplitudes.

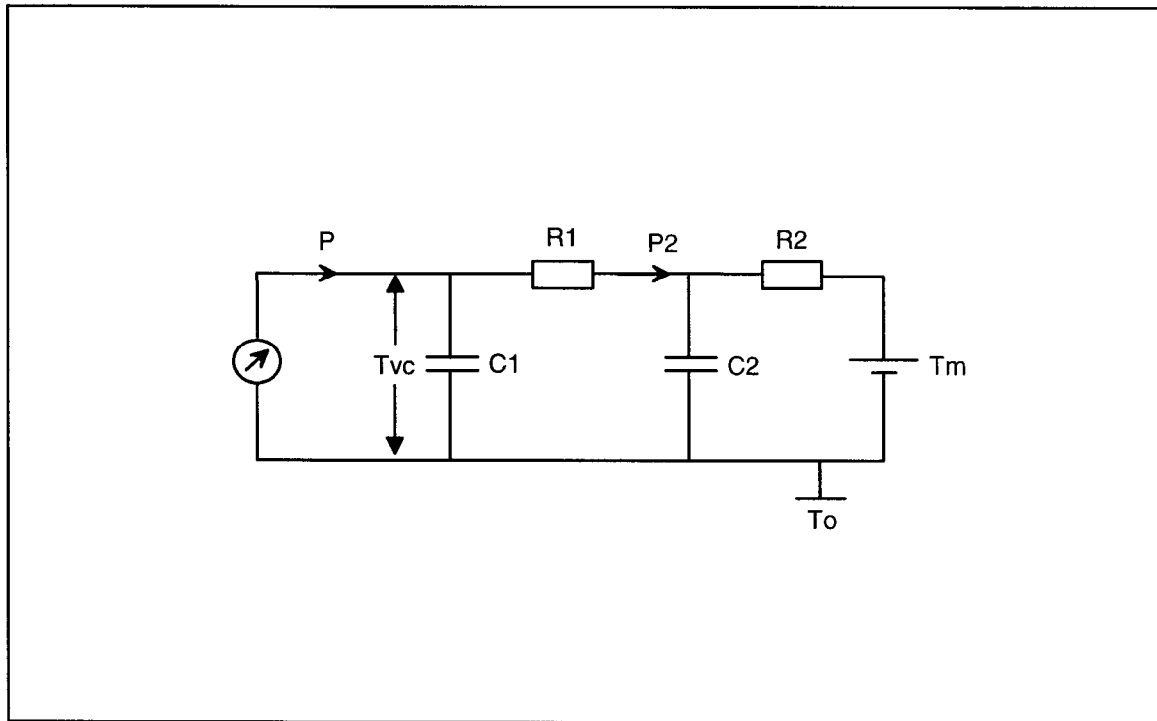

**Figure 5** Basic block diagram of the loudspeaker.

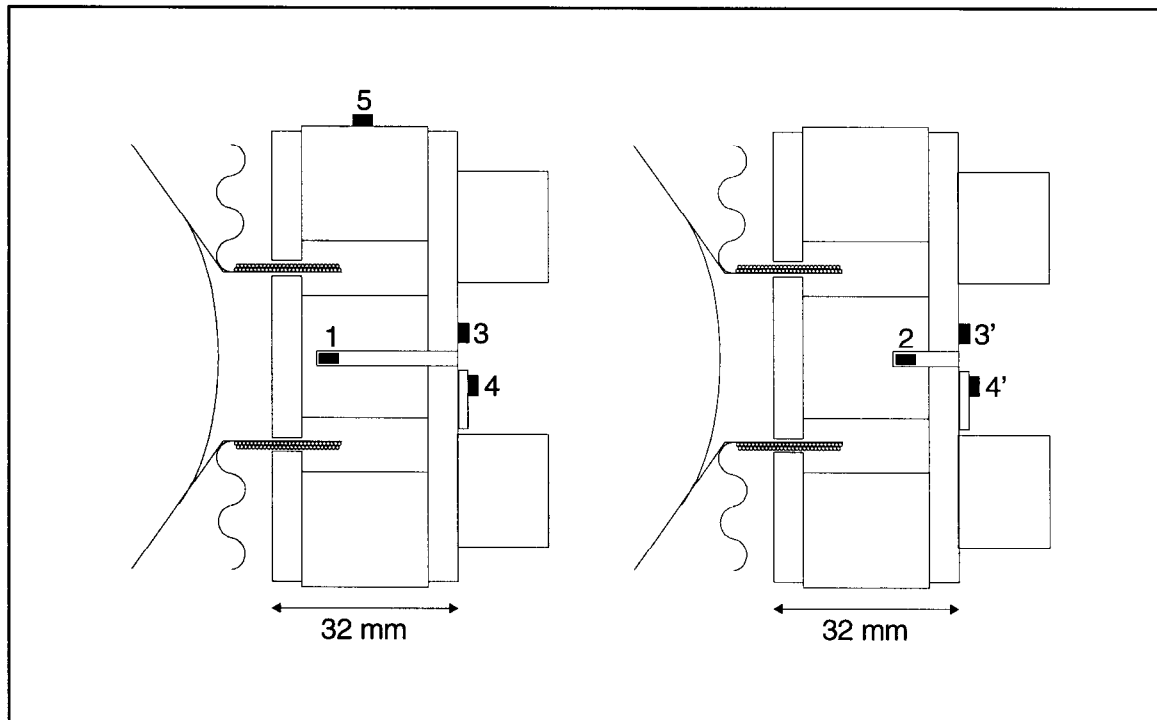

**Figure 6** Third order thermal model of a moving coil loudspeaker.

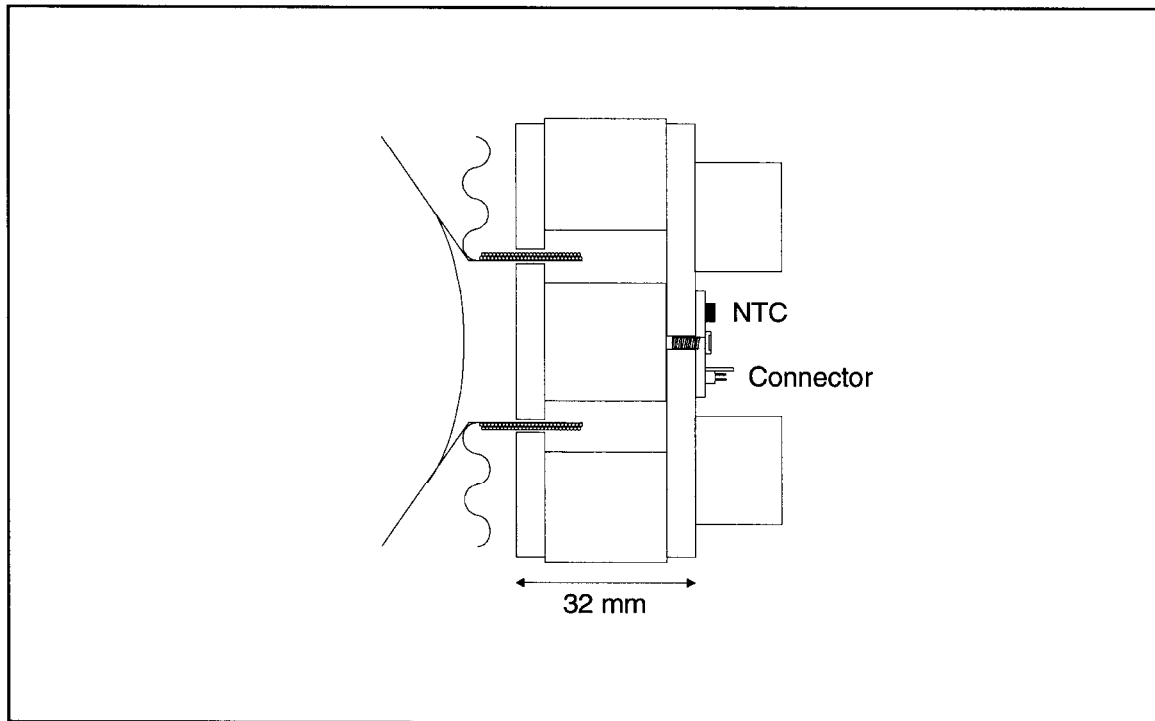



**Figure 7** Thermal model implemented for the bass drivers.



**Figure 8** Investigation into temperature probe placement to measure the magnet temperature.



**Figure 9** Solution for mounting the NTC resistor for measurement of the magnet temperature.

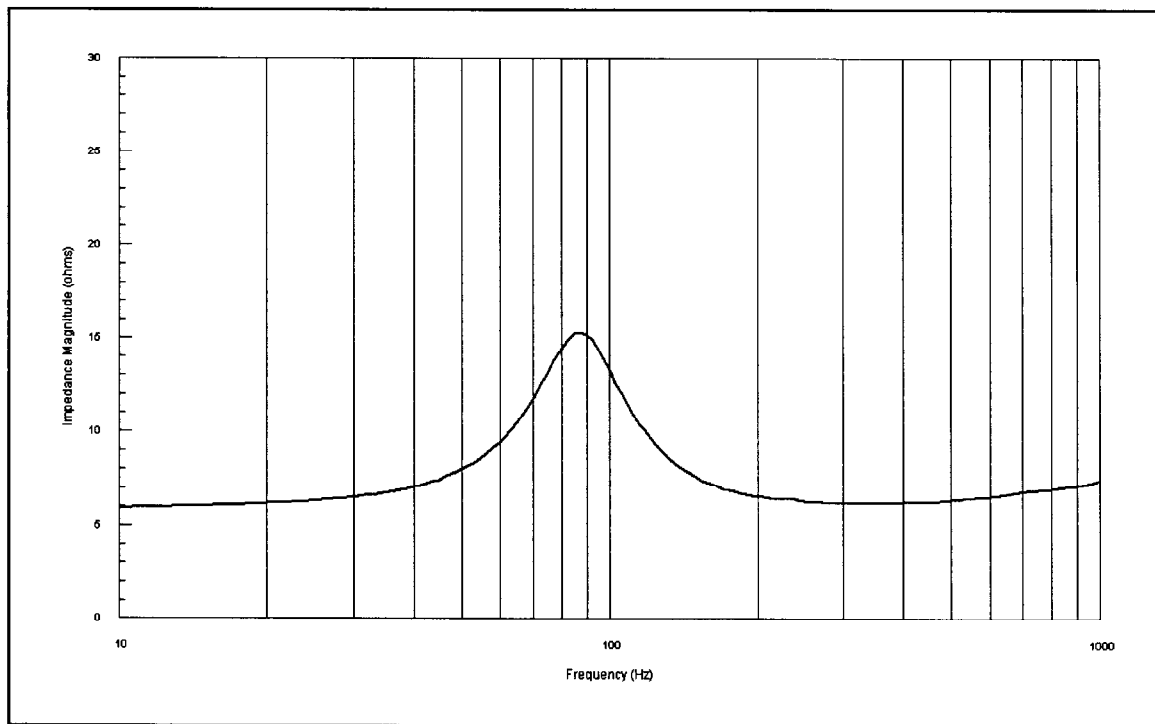

**Figure 10** Impedance of the bass unit in the cabinet in the frequency range of operation.

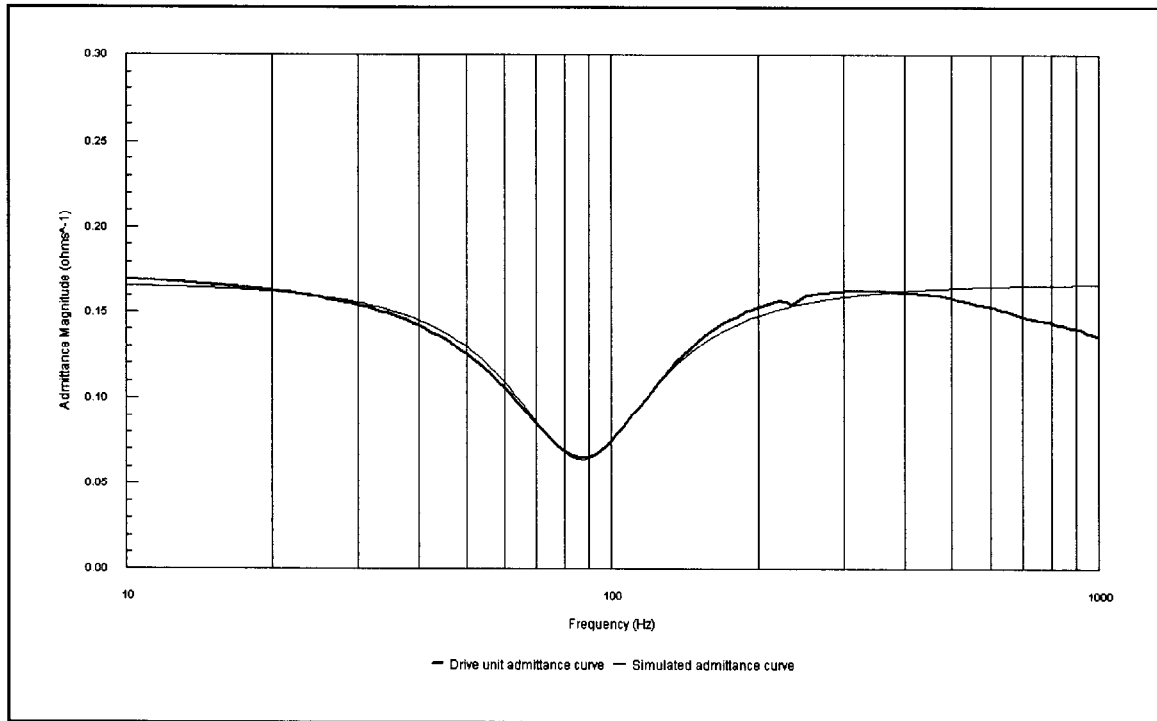

**Figure 11** Drive unit admittance and simulated admittance.

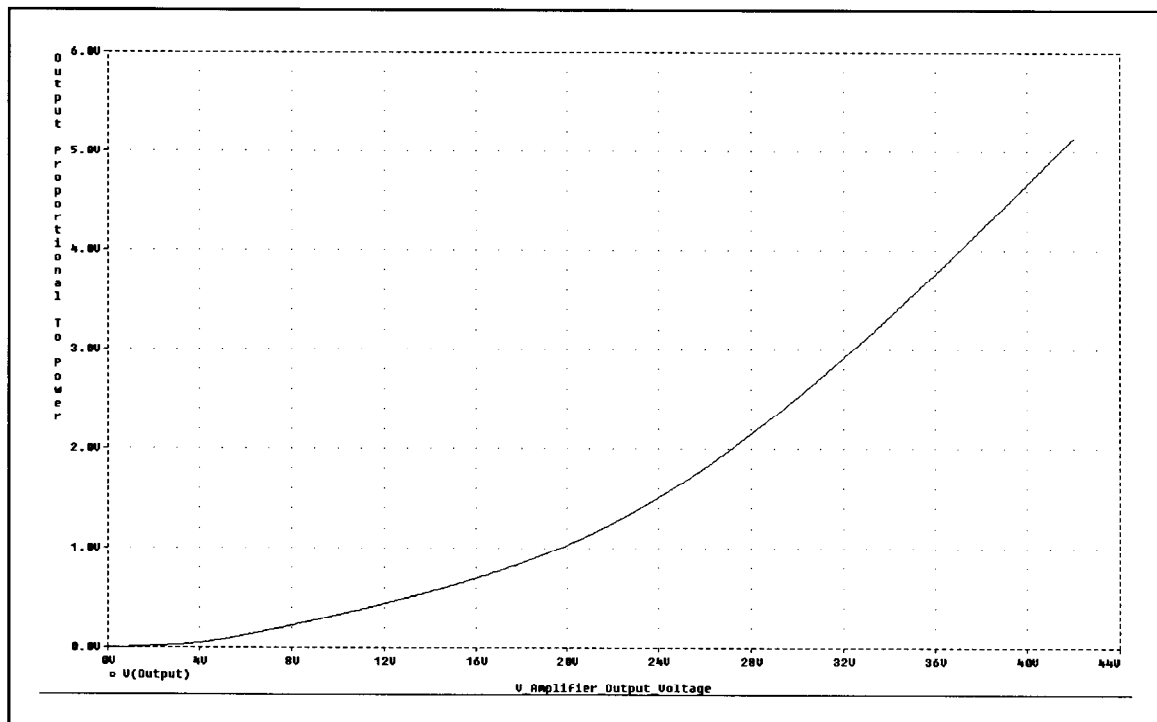

**Figure 12** Circuit response for calculation of power.

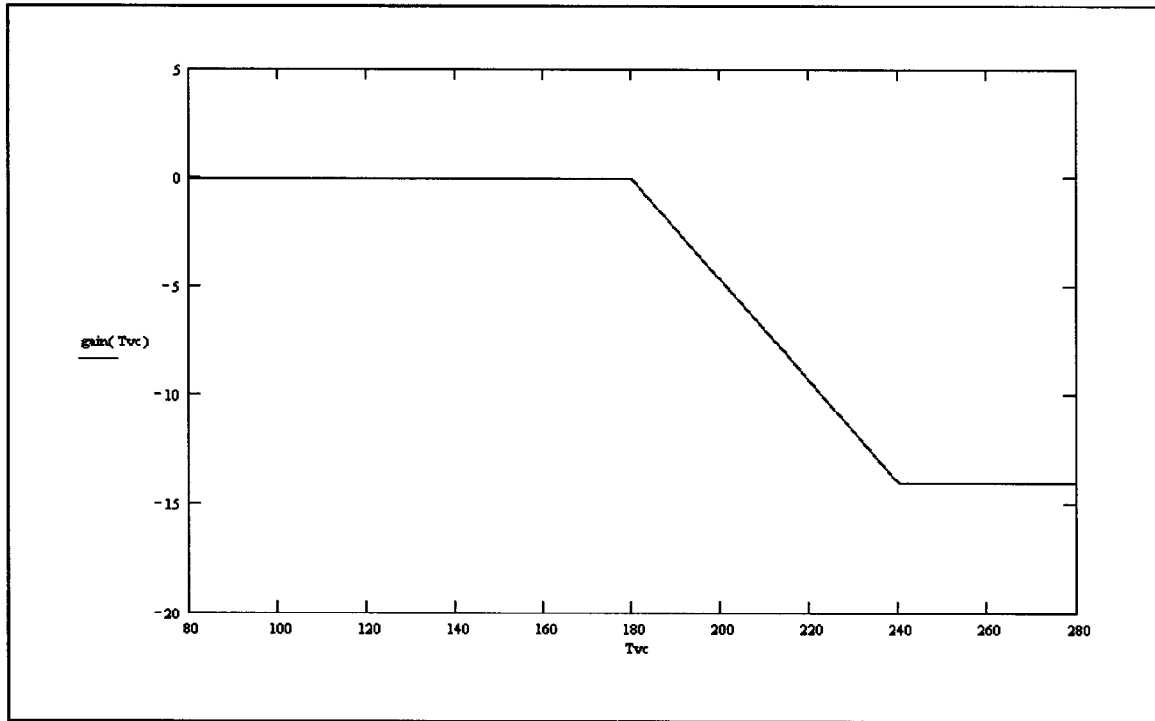

**Figure 13** Approximate gain reduction curve for the bass drivers.

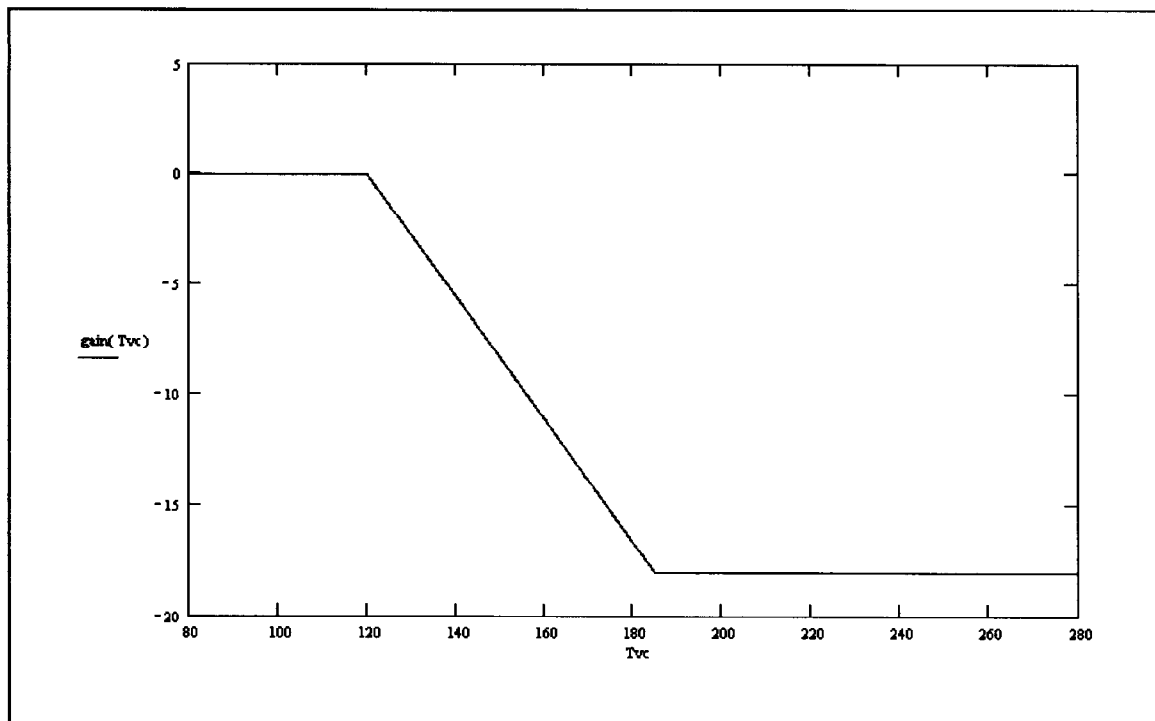

**Figure 14** Approximate gain reduction curve for the midrange.

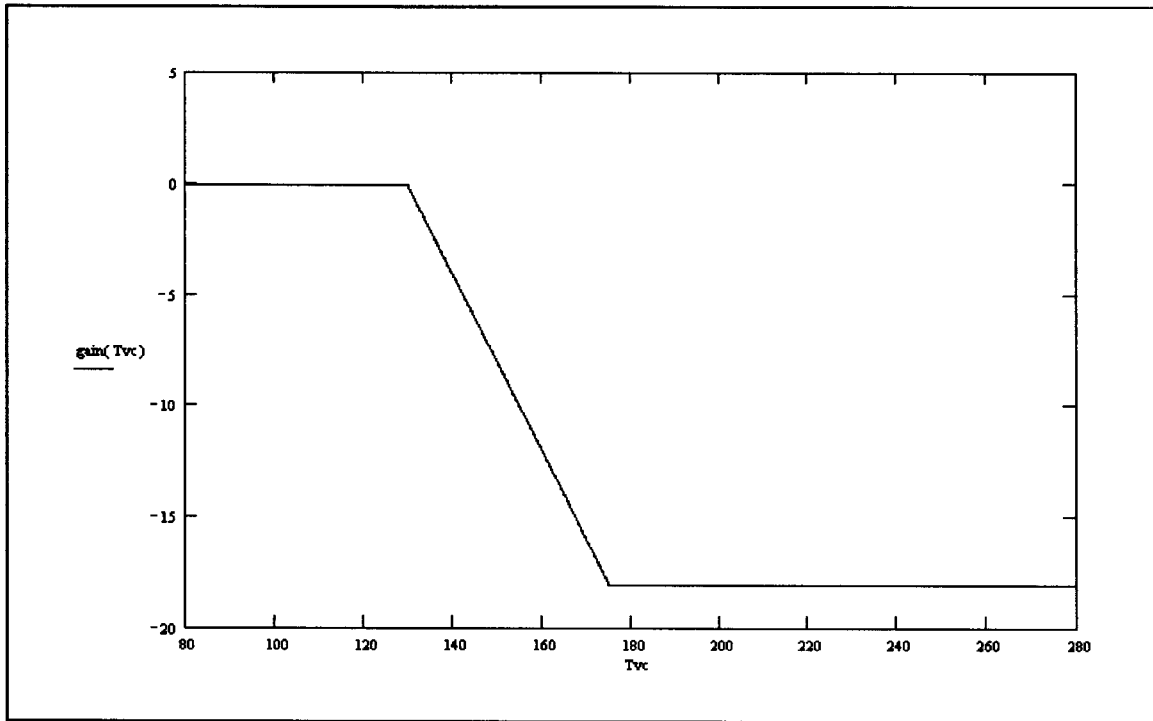

**Figure 15** Approximate gain reduction curve for the tweeter.

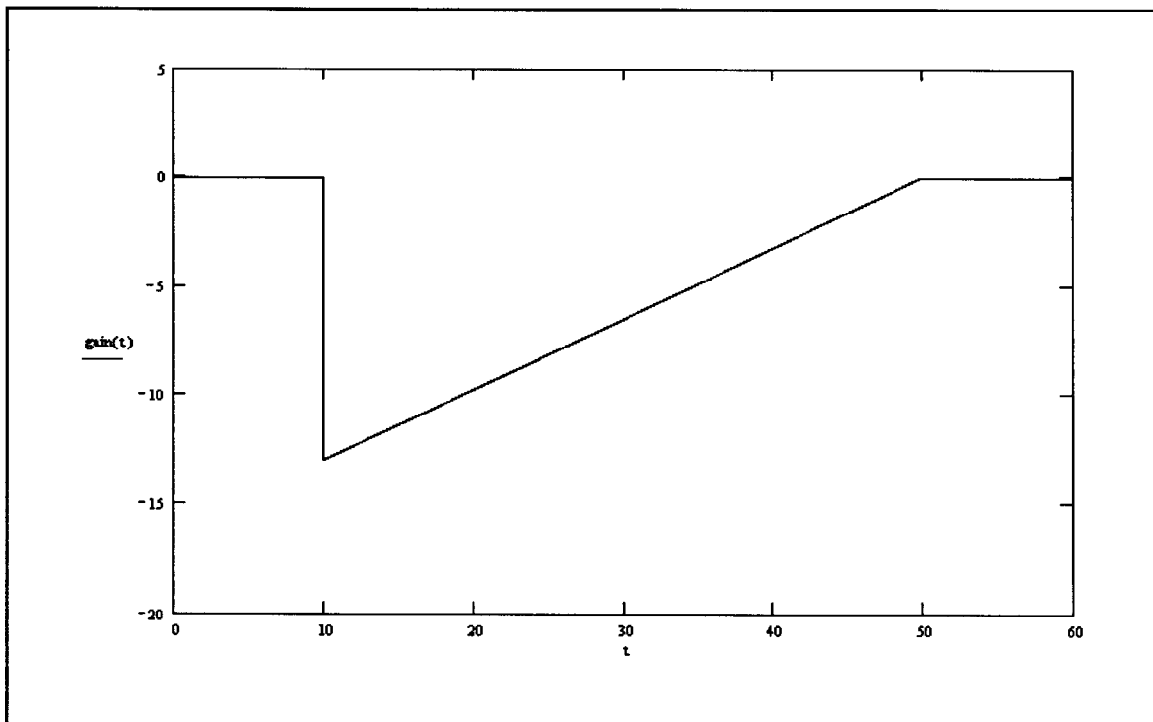

**Figure 16** Approximate gain curve for a single temperature spike occurring at 10s.

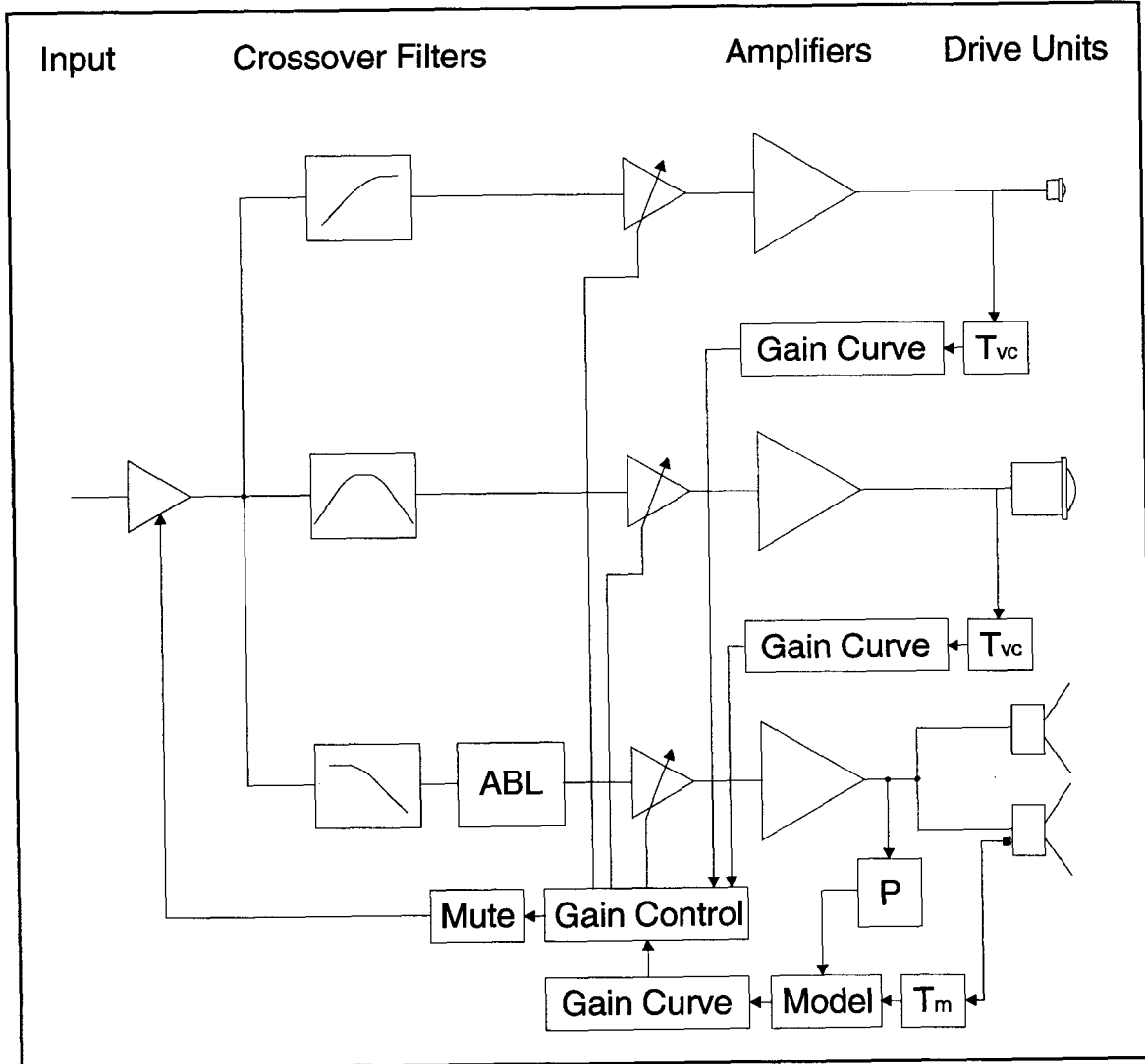

Figure 17 Block diagram of the complete loudspeaker system.